



When it's time for new pencils, you can find inexpensive beginner kits which will have a range of leads. Don't worry it's not actually lead. It's just an old term.

Drawing Lesson: face front.

Hard	<->	Soft
H3 H2 H1 H	HB	B B1 B2 B3
		
light	#2	dark

The Standard Pencil or "Artists Leads (Graphite)"
Everyone knows the #2 Pencil

Art pencils, or leads or graphite can be found as a pencils, or as a lead for a mechanical pencil or a graphic stump. The important detail is to know the difference between a dark (soft) or light (hard) lead.

HB is the average lead also known as #2. Leads which draw a lighter line are hard and stay sharper longer. The higher the number the harder the lead from H1 to H3 +.

Softer than HB are the "black" leads starting with B and getting darker, softer and messier as the number increasesDr

Proportions of a Face

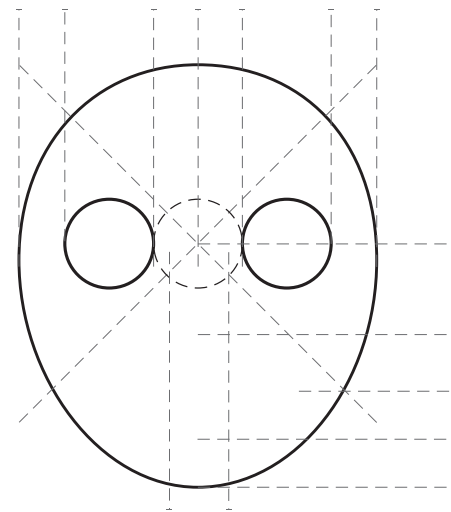
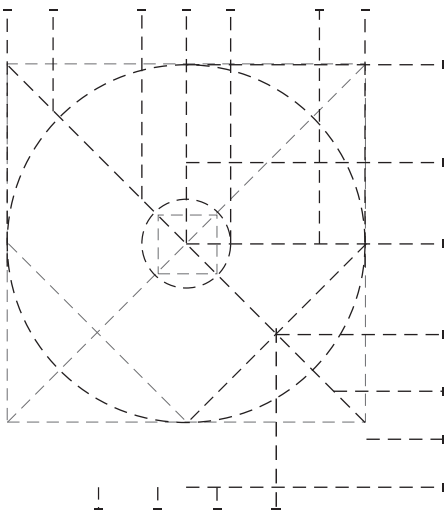
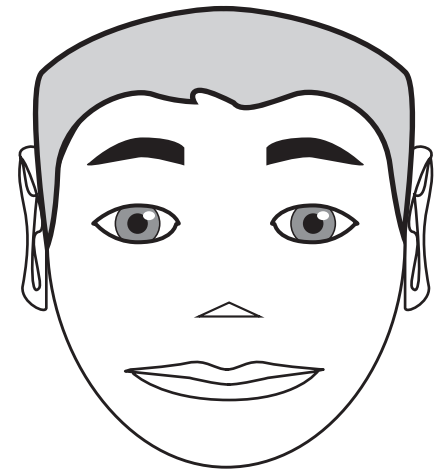
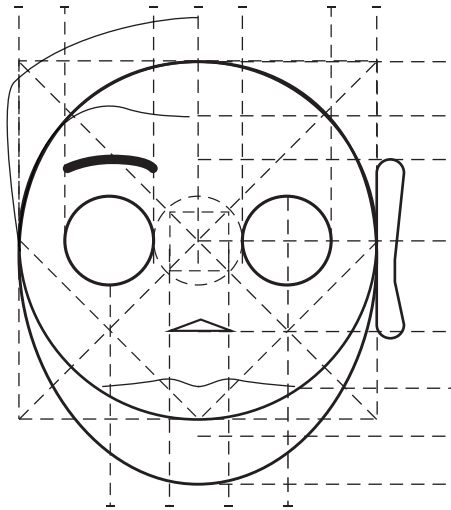
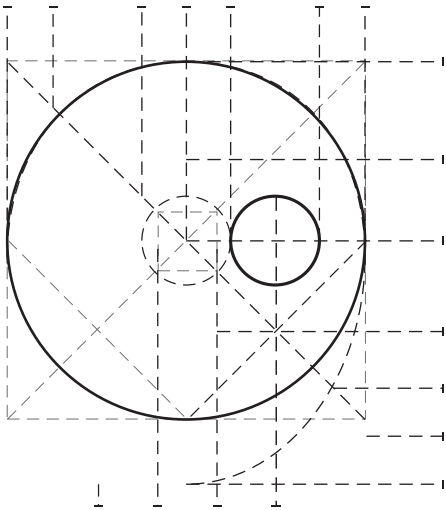
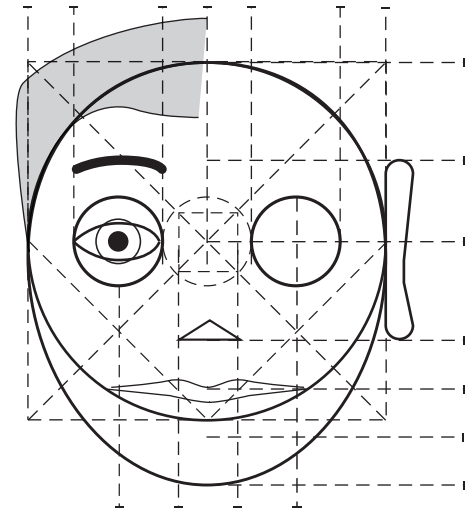

On a separate sheet try this same exercise with different shapes.

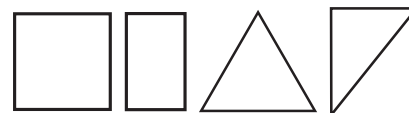

Drawing Lesson: face in profile

Profile of a Face

